

Horizontal Band Saw Survey	
Machine Owner	Worksite
Surveyor's Name	Date of Survey
Supervisor's Name	Room Name or No.
Machine Manufacturer	
Model #	Serial No.
Supply Voltage	No. of Supply Phases (Circle One) 1 or 3
Horsepower	Full Load Amps

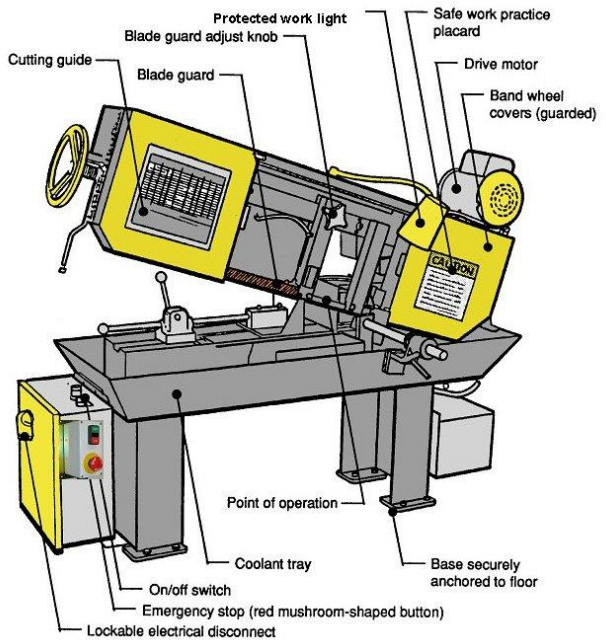

	Yes	No	N/A
1. Are the bandsaw wheels that carry the blade fully enclosed?			
2. Is the power transmission system that drives the blade guarded correctly?			
3. Is the unused portion of the blade guarded ahead of the upper blade guides?			
4. Is the unused portion of the blade guarded beyond the lower blade guides?			
5. Does it have a system that will prevent automatic restart after power outage? (Power outage protection)			
6. Are the electrical system, wires and plug ends compliant?			
7. Does the saw have a latching, red, mushroom shaped E-stop that controls the motor?			
8. Can the machine be securely isolated from power?			
9. Does the machine have a high-friction coating at the operator's position on the floor?			
10. Is the machine secured to prevent moving or tipping?			

Notes
